

Flanged Straight Shank

Available Ex-Stock

Holder Reference Number	Flute Type	Holder Type	Drill Range D	Max Drill Depth L1	Flute Lth L2	New Tool Lth L3	Overall Lth L4	Shank Dia/Length		Pipe Tap	
								D1	L5	G	*
21020S-32FM	Straight	Stub	24.41-35.05	57	88.5	92.1	146.4	32.0	57.9	¼"	⅛"
21025S-32FM	Straight	Stub	30.0-35.05	92	123.4	127.0	181.3	32.0	57.9	¼"	⅛"
22020S-32FM	Straight	Short	24.41-35.05	86	128.6	132.2	186.5	32.0	57.9	¼"	N/A
22025S-32FM	Straight	Short	30.0-35.05	86	128.6	132.2	186.5	32.0	57.9	¼"	N/A
23020H-32FM	Helical	Intermediate	24.41-35.05	137	179.4	183	237.3	32.0	57.9	¼"	N/A
23025H-32FM	Helical	Intermediate	30.0-35.05	137	179.4	183	237.3	32.0	57.9	¼"	N/A
24020H-32FM	Helical	Standard	24.41-35.05	187	230.2	233.8	288.1	32.0	57.9	¼"	N/A
24025H-32FM	Helical	Standard	30.0-35.05	187	230.2	233.8	288.1	32.0	57.9	¼"	N/A
25020H-32FM	Helical	Extended	24.41-35.05	289	331.8	335.4	389.7	32.0	57.9	¼"	N/A
25025H-32FM	Helical	Extended	30.0-35.05	289	331.8	335.4	389.7	32.0	57.9	¼"	N/A
27020S-32FM	Straight	XL	24.41-35.05	511	554.1	557.7	612.0	32.0	57.9	¼"	N/A
29020S-32FM	Straight	3XL	24.41-35.05	692	735.1	738.7	793.0	32.0	57.9	¼"	N/A

*Note: Stub Length includes additional side coolant port.

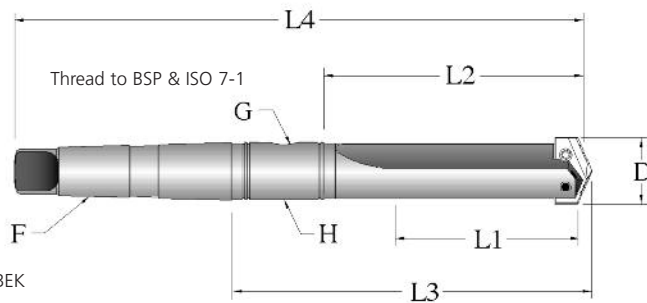

Taper Shank

Available Ex-Stock

Holder Reference Number	Flute Type	Holder Type	Drill Range D	Max Drill Depth L1	Flute Lth L2	New Tool Lth L3	Overall Lth L4	MT F	RCA H	Pipe Tap
										G
22020S-004M	Straight	Short	24.41-35.05	86	114.3	160.4	273.8	4	3SRM	⅛"
22025S-004M	Straight	Short	30.0-35.05	86	114.3	167.6	281	4	4SRM	¼"
23020H-004M	Helical	Intermediate	24.41-35.05	137	165.1	211.2	324.6	4	3SRM	⅛"
23025H-004M	Helical	Intermediate	30.0-35.05	137	165.1	218.4	331.8	4	4SRM	¼"
24020H-004M	Helical	Standard	24.41-35.05	188	215.9	262	375.4	4	3SRM	⅛"
24025H-004M	Helical	Standard	30.0-35.05	188	215.9	269.2	382.6	4	4SRM	¼"
25020H-004M	Helical	Extended	24.41-35.05	289	317.5	363.6	477	4	3SRM	⅛"
25025H-004M	Helical	Extended	30.0-35.05	289	317.5	370.8	484.2	4	4SRM	¼"

For Operating Guidelines refer to pages 62 and 72.



2 Series T-A® Drill Inserts

2 Series GEN2 T-A™ HSS Super Cobalt

Diameter Range 24.41 to 35.05

AMEC's new patented geometry offers substantial increases in penetration rates and tool life. Smoother break-out on through holes, increased drill stability, improved chip formation, and lower drill forces. Particularly suited for good to rigid machining applications, primarily used for drilling exotic and high alloy materials, or general use when the SFM needs to be increased. For use in material hardness up to 350 Bhn 121Kg.



Diameter			Item Number, Coating and Availability							
Ø Inch	Ø Metric (mm)	Ø Decimal	AM200™	Stk.	TiN	Stk.	TiAlN	Stk.	TiCN	Stk.
	24.50	.9646"	452H-24.5	○	452T-24.5	◆	452A-24.5	◆	452N-24.5	◆
3/32"	24.61	.9688"	452H-0031	○	452T-0031	◆	452A-0031	◆	452N-0031	◆
6/64"	25.00	.9843"	452H-25	●	452T-25	◆	452A-25	◆	452N-25	◆
1"	25.40	1.0000"	452H-0100	○	452T-0100	◆	452A-0100	◆	452N-0100	◆
	25.50	1.0004"	452H-25.5	●	452T-25.5	◆	452A-25.5	◆	452N-25.5	◆
1/64"	25.80	1.015"	452H-1.015	○	452T-1.015	◆	452A-1.015	◆	452N-1.015	◆
	26.00	1.0236"	452H-26	●	452T-26	◆	452A-26	◆	452N-26	◆
1/32"	26.19	1.0313"	452H-0101	○	452T-0101	◆	452A-0101	◆	452N-0101	◆
	26.50	1.0433"	452H-26.5	●	452T-26.5	◆	452A-26.5	◆	452N-26.5	◆
1/64"	26.59	1.0469"	452H-1.046	○	452T-1.046	◆	452A-1.046	◆	452N-1.046	◆
1/16"	26.99	1.0625"	452H-0102	○	452T-0102	◆	452A-0102	◆	452N-0102	◆
	27.00	1.0630"	452H-27	●	452T-27	◆	452A-27	◆	452N-27	◆
	27.50	1.0827"	452H-27.5	●	452T-27.5	◆	452A-27.5	◆	452N-27.5	◆
1/32"	27.78	1.0938"	452H-0103	○	452T-0103	◆	452A-0103	◆	452N-0103	◆
	28.00	1.1024"	452H-28	●	452T-28	◆	452A-28	◆	452N-28	◆
1/64"	28.18	1.1094"	452H-1.109	○	452T-1.109	◆	452A-1.109	◆	452N-1.109	◆
	28.50	1.1220"	452H-28.5	●	452T-28.5	◆	452A-28.5	◆	452N-28.5	◆
1/8"	28.58	1.1250"	452H-0104	○	452T-0104	◆	452A-0104	◆	452N-0104	◆
	29.00	1.1417"	452H-29	●	452T-29	◆	452A-29	◆	452N-29	◆
1/32"	29.37	1.1563"	452H-0105	○	452T-0105	◆	452A-0105	◆	452N-0105	◆
	29.50	1.1614"	452H-29.5	●	452T-29.5	◆	452A-29.5	◆	452N-29.5	◆
	30.00	1.1811"	452H-30	●	452T-30	◆	452A-30	◆	452N-30	◆
1/16"	30.16	1.1875"	452H-0106	○	452T-0106	◆	452A-0106	◆	452N-0106	◆
	30.50	1.2007"	452H-30.5	●	452T-30.5	◆	452A-30.5	◆	452N-30.5	◆
1/32"	30.96	1.2188"	452H-0107	○	452T-0107	◆	452A-0107	◆	452N-0107	◆
	31.00	1.2205"	452H-31	●	452T-31	◆	452A-31	◆	452N-31	◆
	31.50	1.2402"	452H-31.5	●	452T-31.5	◆	452A-31.5	◆	452N-31.5	◆
1/4"	31.75	1.2500"	452H-0108	○	452T-0108	◆	452A-0108	◆	452N-0108	◆
	32.00	1.2598"	452H-32	●	452T-32	◆	452A-32	◆	452N-32	◆
	32.50	1.2795"	452H-32.5	●	452T-32.5	◆	452A-32.5	◆	452N-32.5	◆
1/32"	32.54	1.2813"	452H-0109	○	452T-0109	◆	452A-0109	◆	452N-0109	◆
	33.00	1.2992"	452H-33	●	452T-33	◆	452A-33	◆	452N-33	◆
1/16"	33.34	1.3125"	452H-0110	○	452T-0110	◆	452A-0110	◆	452N-0110	◆
	33.50	1.3189"	452H-33.5	●	452T-33.5	◆	452A-33.5	◆	452N-33.5	◆
	34.00	1.3386"	452H-34	●	452T-34	◆	452A-34	◆	452N-34	◆
1/32"	34.13	1.3438"	452H-0111	○	452T-0111	◆	452A-0111	◆	452N-0111	◆
	34.50	1.3583"	452H-34.5	●	452T-34.5	◆	452A-34.5	◆	452N-34.5	◆
1/8"	34.93	1.3750"	452H-0112	○	452T-0112	◆	452A-0112	◆	452N-0112	◆
	35.00	1.3780"	452H-35	●	452T-35	◆	452A-35	◆	452N-35	◆

Supplied in 2 piece packages.

2 Series Standard T-A® HSS CPM-M4

Diameter Range 24.41 to 35.05

Excellent choice for general purpose use, particularly suited for low rigidity difficult machining applications. Recommended for drilling most steels, cast irons, high temperature alloys and aluminium alloys up to 275 Bhn 96kg.



3/32"	24.61	.9688"	132H-0031	◆	132T-0031	○	132A-0031	○	132N-0031	○
6/64"	25.00	.9843"	132H-25	◆	132T-25	●	132A-25	●	132N-25	●
1"	25.40	1.0000"	132H-0100	◆	132T-0100	○	132A-0100	○	132N-0100	○
1/64"	25.80	1.015"	132H-1.015	◆	132T-1.015	○	132A-1.015	○	132N-1.015	○
	26.00	1.0236"	132H-26	◆	132T-26	●	132A-26	●	132N-26	●
1/32"	26.19	1.0313"	132H-0101	◆	132T-0101	○	132A-0101	○	132N-0101	○



2 Series Standard T-A® HSS CPM-M4

Diameter Range 24.41 to 35.05

Diameter			Item Number, Coating and Availability							
Ø Inch	Ø Metric (mm)	Ø Decimal	AM200™	Stk.	TiN	Stk.	TiAlN	Stk.	TiCN	Stk.
1 ³ / ₆₄ "	26.59	1.0469"	132H-1.046	◆	132T-1.046	○	132A-1.046	○	132N-1.046	○
1 ¹ / ₁₆ "	26.99	1.0625"	132H-0102	◆	132T-0102	○	132A-0102	○	132N-0102	○
	27.00	1.0630"	132H-27	◆	132T-27	●	132A-27	●	132N-27	●
1 ³ / ₃₂ "	27.78	1.0938"	132H-0103	◆	132T-0103	○	132A-0103	○	132N-0103	○
	28.00	1.1024"	132H-28	◆	132T-28	●	132A-28	●	132N-28	●
1 ⁷ / ₆₄ "	28.18	1.1094"	132H-1.109	◆	132T-1.109	○	132A-1.109	○	132N-1.109	○
1 ¹ / ₈ "	28.58	1.1250"	132H-0104	◆	132T-0104	○	132A-0104	○	132N-0104	○
	29.00	1.1417"	132H-29	◆	132T-29	●	132A-29	●	132N-29	●
1 ⁵ / ₃₂ "	29.37	1.1563"	132H-0105	◆	132T-0105	○	132A-0105	○	132N-0105	○
	30.00	1.1811"	132H-30	◆	132T-30	●	132A-30	●	132N-30	●
1 ³ / ₁₆ "	30.16	1.1875"	132H-0106	◆	132T-0106	○	132A-0106	○	132N-0106	○
1 ⁷ / ₃₂ "	30.96	1.2188"	132H-0107	◆	132T-0107	○	132A-0107	○	132N-0107	○
	31.00	1.2205"	132H-31	◆	132T-31	●	132A-31	●	132N-31	●
1 ¹ / ₄ "	31.75	1.2500"	132H-0108	◆	132T-0108	○	132A-0108	○	132N-0108	○
	32.00	1.2598"	132H-32	◆	132T-32	●	132A-32	●	132N-32	●
1 ⁹ / ₃₂ "	32.54	1.2813"	132H-0109	◆	132T-0109	○	132A-0109	○	132N-0109	○
	33.00	1.2992"	132H-33	◆	132T-33	●	132A-33	●	132N-33	●
1 ⁵ / ₁₆ "	33.34	1.3125"	132H-0110	◆	132T-0110	○	132A-0110	○	132N-0110	○
	34.00	1.3386"	132H-34	◆	132T-34	●	132A-34	●	132N-34	●
1 ¹¹ / ₃₂ "	34.13	1.3438"	132H-0111	◆	132T-0111	○	132A-0111	○	132N-0111	○
1 ³ / ₈ "	34.93	1.3750"	132H-0112	◆	132T-0112	○	132A-0112	○	132N-0112	○
	35.00	1.3780"	132H-35	◆	132T-35	●	132A-35	●	132N-35	●

Supplied in 2 piece packages.

2 Series Standard T-A® Super Cobalt

Diameter Range 24.41 to 35.05

Particularly suited for good to rigid machining applications, primarily used for drilling exotic and high alloy materials, or general use when the SFM needs to be increased. For use in material hardness up to 350 Bhn 121Kg.



	24.50	.9646"	152H-24.5	◆	152T-24.5	○	152A-24.5	●	152N-24.5	○
3 ¹ / ₃₂ "	24.61	.9688"	152H-0031	◆	152T-0031	○	152A-0031	○	152N-0031	○
6 ³ / ₆₄ "	25.00	.9843"	152H-25	◆	152T-25	●	152A-25	●	152N-25	●
1"	25.40	1.0000"	152H-0100	◆	152T-0100	○	152A-0100	○	152N-0100	○
	25.50	1.004"	152H-25.5	◆	152T-25.5	○	152A-25.5	●	152N-25.5	○
1 ¹ / ₆₄ "	25.80	1.015"	152H-1.015	◆	152T-1.015	○	152A-1.015	○	152N-1.015	○
	26.00	1.0236"	152H-26	◆	152T-26	●	152A-26	●	152N-26	●
1 ¹ / ₃₂ "	26.19	1.0313"	152H-0101	◆	152T-0101	○	152A-0101	○	152N-0101	○
	26.50	1.0433"	152H-26.5	◆	152T-26.5	○	152A-26.5	●	152N-26.5	○
1 ³ / ₆₄ "	26.59	1.0469"	152H-1.046	◆	152T-1.046	○	152A-1.046	○	152N-1.046	○
1 ¹ / ₁₆ "	26.99	1.0625"	152H-0102	◆	152T-0102	○	152A-0102	○	152N-0102	○
	27.00	1.0630"	152H-27	◆	152T-27	●	152A-27	●	152N-27	●
	27.50	1.0827"	152H-27.5	◆	152T-27.5	○	152A-27.5	●	152N-27.5	○
1 ³ / ₃₂ "	27.78	1.0938"	152H-0103	◆	152T-0103	○	152A-0103	○	152N-0103	○
	28.00	1.1024"	152H-28	◆	152T-28	●	152A-28	●	152N-28	●
1 ⁷ / ₆₄ "	28.18	1.1094"	152H-1.109	◆	152T-1.109	○	152A-1.109	○	152N-1.109	○
	28.50	1.1220"	152H-28.5	◆	152T-28.5	○	152A-28.5	●	152N-28.5	○
1 ¹ / ₈ "	28.58	1.1250"	152H-0104	◆	152T-0104	○	152A-0104	○	152N-0104	○
	29.00	1.1417"	152H-29	◆	152T-29	●	152A-29	●	152N-29	●
1 ⁵ / ₃₂ "	29.37	1.1563"	152H-0105	◆	152T-0105	○	152A-0105	○	152N-0105	○
	29.50	1.1614"	152H-29.5	◆	152T-29.5	○	152A-29.5	●	152N-29.5	○



2 Series T-A® Drill Inserts

2 Series Standard T-A® Super Cobalt

Diameter Range 24.41 to 35.05

Diameter			Item Number, Coating and Availability							
Ø Inch	Ø Metric (mm)	Ø Decimal	AM200™	Stk.	TiN	Stk.	TiAlN	Stk.	TiCN	Stk.
	30.00	1.1811"	152H-30	◆	152T-30	●	152A-30	●	152N-30	●
1 3/16"	30.16	1.1875"	152H-0106	◆	152T-0106	○	152A-0106	○	152N-0106	○
	30.50	1.2007"	152H-30.5	◆	152T-30.5	○	152A-30.5	●	152N-30.5	○
1 1/32"	30.96	1.2188"	152H-0107	◆	152T-0107	○	152A-0107	○	152N-0107	○
	31.00	1.2205"	152H-31	◆	152T-31	●	152A-31	●	152N-31	●
	31.50	1.2402"	152H-31.5	◆	152T-31.5	○	152A-31.5	●	152N-31.5	○
1 1/4"	31.75	1.2500"	152H-0108	◆	152T-0108	○	152A-0108	○	152N-0108	○
	32.00	1.2598"	152H-32	◆	152T-32	●	152A-32	●	152N-32	●
	32.50	1.2795"	152H-32.5	◆	152T-32.5	○	152A-32.5	●	152N-32.5	○
1 9/32"	32.54	1.2813"	152H-0109	◆	152T-0109	○	152A-0109	○	152N-0109	○
	33.00	1.2992"	152H-33	◆	152T-33	●	152A-33	●	152N-33	●
1 5/16"	33.34	1.3125"	152H-0110	◆	152T-0110	○	152A-0110	○	152N-0110	○
	33.50	1.3189"	152H-33.5	◆	152T-33.5	○	152A-33.5	●	152N-33.5	○
	34.00	1.3386"	152H-34	◆	152T-34	●	152A-34	●	152N-34	●
1 1/32"	34.13	1.3438"	152H-0111	◆	152T-0111	○	152A-0111	○	152N-0111	○
	34.50	1.3583"	152H-34.5	◆	152T-34.5	○	152A-34.5	●	152N-34.5	○
1 3/8"	34.93	1.3750"	152H-0112	◆	152T-0112	○	152A-0112	○	152N-0112	○
	35.00	1.3780"	152H-35	◆	152T-35	●	152A-35	●	152N-35	●

2 Series Standard T-A® HSS Premium Cobalt

Diameter Range 24.41 to 35.05

Particularly suited for rigid machining applications primarily used for drilling exotic and high alloy materials, or general use when the SFM needs to be increased. For use in material hardness up to 400 Bhn 139Kg.



3 1/32"	24.61	.9688"	182H-0031	◆	182T-0031	○	182A-0031	○	182N-0031	○
63/64"	25.00	.9843"	182H-25	◆	182T-25	●	182A-25	●	182N-25	●
1"	25.40	1.0000"	182H-0100	◆	182T-0100	○	182A-0100	○	182N-0100	○
1 1/64"	25.80	1.015"	182H-1.015	◆	182T-1.015	○	182A-1.015	○	182N-1.015	○
	26.00	1.0236"	182H-26	◆	182T-26	●	182A-26	●	182N-26	●
1 1/32"	26.19	1.0313"	182H-0101	◆	182T-0101	○	182A-0101	○	182N-0101	○
1 3/64"	26.59	1.0469"	182H-1.046	◆	182T-1.046	○	182A-1.046	○	182N-1.046	○
1 1/16"	26.99	1.0625"	182H-0102	◆	182T-0102	○	182A-0102	○	182N-0102	○
	27.00	1.0630"	182H-27	◆	182T-27	●	182A-27	●	182N-27	●
1 3/32"	27.78	1.0938"	182H-0103	◆	182T-0103	○	182A-0103	○	182N-0103	○
	28.00	1.1024"	182H-28	◆	182T-28	●	182A-28	●	182N-28	●
1 7/64"	28.18	1.1094"	182H-1.109	◆	182T-1.109	○	182A-1.109	○	182N-1.109	○
1 1/8"	28.58	1.1250"	182H-0104	◆	182T-0104	○	182A-0104	○	182N-0104	○
	29.00	1.1417"	182H-29	◆	182T-29	●	182A-29	●	182N-29	●
1 5/32"	29.37	1.1563"	182H-0105	◆	182T-0105	○	182A-0105	○	182N-0105	○
	30.00	1.1811"	182H-30	◆	182T-30	●	182A-30	●	182N-30	●
1 3/16"	30.16	1.1875"	182H-0106	◆	182T-0106	○	182A-0106	○	182N-0106	○
1 1/32"	30.96	1.2188"	182H-0107	◆	182T-0107	○	182A-0107	○	182N-0107	○
	31.00	1.2205"	182H-31	◆	182T-31	●	182A-31	●	182N-31	●
1 1/4"	31.75	1.2500"	182H-0108	◆	182T-0108	○	182A-0108	○	182N-0108	○
	32.00	1.2598"	182H-32	◆	182T-32	●	182A-32	●	182N-32	●
1 9/32"	32.54	1.2813"	182H-0109	◆	182T-0109	○	182A-0109	○	182N-0109	○
	33.00	1.2992"	182H-33	◆	182T-33	●	182A-33	●	182N-33	●
1 5/16"	33.34	1.3125"	182H-0110	◆	182T-0110	○	182A-0110	○	182N-0110	○
	34.00	1.3386"	182H-34	◆	182T-34	●	182A-34	●	182N-34	●
1 11/32"	34.13	1.3438"	182H-0111	◆	182T-0111	○	182A-0111	○	182N-0111	○
1 3/8"	34.93	1.3750"	182H-0112	◆	182T-0112	○	182A-0112	○	182N-0112	○
	35.00	1.3780"	182H-35	◆	182T-35	●	182A-35	●	182N-35	●

Supplied in 2 piece packages.

2 Series T-A® Drill Inserts



2 Series GEN2 T-A™ K20 Carbide

Diameter Range 24.41 to 35.05

AMEC's new patented geometry offers substantial increases in penetration rates and tool life. Smoother break-out on through holes, increased drill stability, improved chip formation, and lower drill forces. Excellent choice for drilling high temperature alloys, titanium alloys, cast aluminium, wrought aluminium, SG/Nodular cast iron, grey/white iron, aluminium bronze, brass, copper, and certain stainless steels refer to technical section.



Diameter			Item Number, Coating and Availability							
Ø Inch	Ø Metric (mm)	Ø Decimal	AM200™	Stk.	TiN	Stk.	TiAlN	Stk.	TiCN	Stk.
	24.50	.9646"	4C22H-24.5	●	4C22T-24.5	◆	4C22A-24.5	◆	4C22N-24.5	◆
3 1/32"	24.61	.9688"	4C22H-0031	○	4C22T-0031	◆	4C22A-0031	◆	4C22N-0031	◆
6 3/64"	25.00	.9843"	4C22H-25	●	4C22T-25	◆	4C22A-25	◆	4C22N-25	◆
1"	25.40	1.0000"	4C22H-0100	○	4C22T-0100	◆	4C22A-0100	◆	4C22N-0100	◆
	25.50	1.004"	4C22H-25.5	●	4C22T-25.5	◆	4C22A-25.5	◆	4C22N-25.5	◆
	26.00	1.0236"	4C22H-26	●	4C22T-26	◆	4C22A-26	◆	4C22N-26	◆
1 1/32"	26.19	1.0313"	4C22H-0101	○	4C22T-0101	◆	4C22A-0101	◆	4C22N-0101	◆
	26.50	1.0433"	4C22H-26.5	●	4C22T-26.5	◆	4C22A-26.5	◆	4C22N-26.5	◆
1 3/64"	26.59	1.0469"	4C22H-1.046	○	4C22T-1.046	◆	4C22A-1.046	◆	4C22N-1.046	◆
1 1/16"	26.99	1.0625"	4C22H-0102	○	4C22T-0102	◆	4C22A-0102	◆	4C22N-0102	◆
	27.00	1.0630"	4C22H-27	○	4C22T-27	◆	4C22A-27	◆	4C22N-27	◆
	27.50	1.0827"	4C22H-27.5	●	4C22T-27.5	◆	4C22A-27.5	◆	4C22N-27.5	◆
1 3/32"	27.78	1.0938"	4C22H-0103	○	4C22T-0103	◆	4C22A-0103	◆	4C22N-0103	◆
	28.00	1.1024"	4C22H-28	●	4C22T-28	◆	4C22A-28	◆	4C22N-28	◆
1 7/64"	28.18	1.1094"	4C22H-1.109	○	4C22T-1.109	◆	4C22A-1.109	◆	4C22N-1.109	◆
	28.50	1.1220"	4C22H-28.5	●	4C22T-28.5	◆	4C22A-28.5	◆	4C22N-28.5	◆
1 1/8"	28.58	1.1250"	4C22H-0104	○	4C22T-0104	◆	4C22A-0104	◆	4C22N-0104	◆
	29.00	1.1417"	4C22H-29	●	4C22T-29	◆	4C22A-29	◆	4C22N-29	◆
1 5/32"	29.37	1.1563"	4C22H-0105	◆	4C22T-0105	◆	4C22A-0105	◆	4C22N-0105	◆
	29.50	1.1614"	4C22H-29.5	●	4C22T-29.5	◆	4C22A-29.5	◆	4C22N-29.5	◆
	30.00	1.1811"	4C22H-30	●	4C22T-30	◆	4C22A-30	◆	4C22N-30	◆
1 3/16"	30.16	1.1875"	4C22H-0106	◆	4C22T-0106	◆	4C22A-0106	◆	4C22N-0106	◆
	30.50	1.2007"	4C22H-30.5	●	4C22T-30.5	◆	4C22A-30.5	◆	4C22N-30.5	◆
1 7/32"	30.96	1.2188"	4C22H-0107	○	4C22T-0107	◆	4C22A-0107	◆	4C22N-0107	◆
	31.00	1.2205"	4C22H-31	●	4C22T-31	◆	4C22A-31	◆	4C22N-31	◆
	31.50	1.2402"	4C22H-31.5	●	4C22T-31.5	◆	4C22A-31.5	◆	4C22N-31.5	◆
1 1/4"	31.75	1.2500"	4C22H-0108	◆	4C22T-0108	◆	4C22A-0108	◆	4C22N-0108	◆
	32.00	1.2598"	4C22H-32	●	4C22T-32	◆	4C22A-32	◆	4C22N-32	◆
	32.50	1.2795"	4C22H-32.5	●	4C22T-32.5	◆	4C22A-32.5	◆	4C22N-32.5	◆
1 9/32"	32.54	1.2813"	4C22H-0109	○	4C22T-0109	◆	4C22A-0109	◆	4C22N-0109	◆
	33.00	1.2992"	4C22H-33	●	4C22T-33	◆	4C22A-33	◆	4C22N-33	◆
1 5/16"	33.34	1.3125"	4C22H-0110	◆	4C22T-0110	◆	4C22A-0110	◆	4C22N-0110	◆
	33.50	1.3189"	4C22H-33.5	●	4C22T-33.5	◆	4C22A-33.5	◆	4C22N-33.5	◆
	34.00	1.3386"	4C22H-34	●	4C22T-34	◆	4C22A-34	◆	4C22N-34	◆
1 11/32"	34.13	1.3438"	4C22H-0111	○	4C22T-0111	◆	4C22A-0111	◆	4C22N-0111	◆
	34.50	1.3583"	4C22H-34.5	●	4C22T-34.5	◆	4C22A-34.5	◆	4C22N-34.5	◆
1 3/8"	34.93	1.3750"	4C22H-0112	◆	4C22T-0112	◆	4C22A-0112	◆	4C22N-0112	◆
	35.00	1.3780"	4C22H-35	●	4C22T-35	◆	4C22A-35	◆	4C22N-35	◆

Supplied in 2 piece packages.

Stk. - Stock Availability.

- Stock Item.
- Stocked in limited quantities, advanced planning is recommended.
- ◆ Non-stock standard. Normal delivery 5 to 6 weeks.

Any non-standard size available.



2 Series T-A® Drill Inserts

2 Series GEN2 T-A™ K35 Carbide

Diameter Range 24.41 to 35.05

AMEC's new patented geometry offers substantial increases in penetration rates and tool life. Smoother break-out on through holes, increased drill stability, improved chip formation, and lower drill forces. Excellent choice for drilling, free machining steel, low/medium carbon steels, alloy steels, high strength steels, tool steels, hardened steels, and certain stainless steels refer to technical section.



Diameter			Item Number, Coating and Availability							
Ø Inch	Ø Metric (mm)	Ø Decimal	AM200™	Stk.	TiN	Stk.	TiAlN	Stk.	TiCN	Stk.
	24.50	.9646"	4C12H-24.5	●	4C12T-24.5	◆	4C12A-24.5	◆	4C12N-24.5	◆
3 ¹ / ₃₂ "	24.61	.9688"	4C12H-0031	○	4C12T-0031	◆	4C12A-0031	◆	4C12N-0031	◆
6 ³ / ₆₄ "	25.00	.9843"	4C12H-25	●	4C12T-25	◆	4C12A-25	◆	4C12N-25	◆
1"	25.40	1.0000"	4C12H-0100	○	4C12T-0100	◆	4C12A-0100	◆	4C12N-0100	◆
	25.50	1.0004"	4C12H-25.5	●	4C12T-25.5	◆	4C12A-25.5	◆	4C12N-25.5	◆
	26.00	1.0236"	4C12H-26	●	4C12T-26	◆	4C12A-26	◆	4C12N-26	◆
1 ¹ / ₃₂ "	26.19	1.0313"	4C12H-0101	○	4C12T-0101	◆	4C12A-0101	◆	4C12N-0101	◆
	26.50	1.0433"	4C12H-26.5	●	4C12T-26.5	◆	4C12A-26.5	◆	4C12N-26.5	◆
1 ³ / ₆₄ "	26.59	1.0469"	4C12H-1.046	○	4C12T-1.046	◆	4C12A-1.046	◆	4C12N-1.046	◆
1 ¹ / ₁₆ "	26.99	1.0625"	4C12H-0102	○	4C12T-0102	◆	4C12A-0102	◆	4C12N-0102	◆
	27.00	1.0630"	4C12H-27	●	4C12T-27	◆	4C12A-27	◆	4C12N-27	◆
	27.50	1.0827"	4C12H-27.5	●	4C12T-27.5	◆	4C12A-27.5	◆	4C12N-27.5	◆
1 ³ / ₃₂ "	27.78	1.0938"	4C12H-0103	○	4C12T-0103	◆	4C12A-0103	◆	4C12N-0103	◆
	28.00	1.1024"	4C12H-28	●	4C12T-28	◆	4C12A-28	◆	4C12N-28	◆
1 ⁷ / ₆₄ "	28.18	1.1094"	4C12H-1.109	○	4C12T-1.109	◆	4C12A-1.109	◆	4C12N-1.109	◆
	28.50	1.1220"	4C12H-28.5	●	4C12T-28.5	◆	4C12A-28.5	◆	4C12N-28.5	◆
1 ¹ / ₈ "	28.58	1.1250"	4C12H-0104	○	4C12T-0104	◆	4C12A-0104	◆	4C12N-0104	◆
	29.00	1.1417"	4C12H-29	●	4C12T-29	◆	4C12A-29	◆	4C12N-29	◆
1 ⁵ / ₃₂ "	29.37	1.1563"	4C12H-0105	○	4C12T-0105	◆	4C12A-0105	◆	4C12N-0105	◆
	29.50	1.1614"	4C12H-29.5	●	4C12T-29.5	◆	4C12A-29.5	◆	4C12N-29.5	◆
	30.00	1.1811"	4C12H-30	●	4C12T-30	◆	4C12A-30	◆	4C12N-30	◆
1 ³ / ₁₆ "	30.16	1.1875"	4C12H-0106	○	4C12T-0106	◆	4C12A-0106	◆	4C12N-0106	◆
	30.50	1.2007"	4C12H-30.5	●	4C12T-30.5	◆	4C12A-30.5	◆	4C12N-30.5	◆
1 ⁷ / ₃₂ "	30.96	1.2188"	4C12H-0107	○	4C12T-0107	◆	4C12A-0107	◆	4C12N-0107	◆
	31.00	1.2205"	4C12H-31	●	4C12T-31	◆	4C12A-31	◆	4C12N-31	◆
	31.50	1.2402"	4C12H-31.5	●	4C12T-31.5	◆	4C12A-31.5	◆	4C12N-31.5	◆
1 ¹ / ₄ "	31.75	1.2500"	4C12H-0108	○	4C12T-0108	◆	4C12A-0108	◆	4C12N-0108	◆
	32.00	1.2598"	4C12H-32	●	4C12T-32	◆	4C12A-32	◆	4C12N-32	◆
	32.50	1.2795"	4C12H-32.5	●	4C12T-32.5	◆	4C12A-32.5	◆	4C12N-32.5	◆
1 ⁹ / ₃₂ "	32.54	1.2813"	4C12H-0109	○	4C12T-0109	◆	4C12A-0109	◆	4C12N-0109	◆
	33.00	1.2992"	4C12H-33	●	4C12T-33	◆	4C12A-33	◆	4C12N-33	◆
1 ⁵ / ₁₆ "	33.34	1.3125"	4C12H-0110	○	4C12T-0110	◆	4C12A-0110	◆	4C12N-0110	◆
	33.50	1.3189"	4C12H-33.5	●	4C12T-33.5	◆	4C12A-33.5	◆	4C12N-33.5	◆
	34.00	1.3386"	4C12H-34	●	4C12T-34	◆	4C12A-34	◆	4C12N-34	◆
1 ¹¹ / ₃₂ "	34.13	1.3438"	4C12H-0111	○	4C12T-0111	◆	4C12A-0111	◆	4C12N-0111	◆
	34.50	1.3583"	4C12H-34.5	●	4C12T-34.5	◆	4C12A-34.5	◆	4C12N-34.5	◆
1 ³ / ₈ "	34.93	1.3750"	4C12H-0112	○	4C12T-0112	◆	4C12A-0112	◆	4C12N-0112	◆
	35.00	1.3780"	4C12H-35	●	4C12T-35	◆	4C12A-35	◆	4C12N-35	◆

Supplied in 2 piece packages.

2 Series Standard T-A® K20 Carbide

Diameter Range 24.41 to 35.05

Excellent choice for drilling high temperature alloys, titanium alloys, cast aluminium, wrought aluminium, SG/Nodular cast iron, grey/white iron, aluminium bronze, brass, copper, and certain stainless steels refer to technical section.



	24.50	.9646"	1C22H-24.5	◆	1C22T-24.5	○	1C22A-24.5	●	1C22N-24.5	◆
3 ¹ / ₃₂ "	24.61	.9688"	1C22H-0031	◆	1C22T-0031	○	1C22A-0031	○	1C22N-0031	◆
6 ³ / ₆₄ "	25.00	.9843"	1C22H-25	◆	1C22T-25	●	1C22A-25	●	1C22N-25	◆
1"	25.40	1.0000"	1C22H-0100	◆	1C22T-0100	○	1C22A-0100	○	1C22N-0100	◆
	25.50	1.004"	1C22H-25.5	◆	1C22T-25.5	○	1C22A-25.5	●	1C22N-25.5	◆
	26.00	1.0236"	1C22H-26	◆	1C22T-26	●	1C22A-26	●	1C22N-26	◆
1 ¹ / ₃₂ "	26.19	1.0313"	1C22H-0101	◆	1C22T-0101	○	1C22A-0101	○	1C22N-0101	◆



2 Series Standard T-A® K20 Carbide

Diameter Range 24.41 to 35.05

Diameter			Item Number, Coating and Availability							
Ø Inch	Ø Metric (mm)	Ø Decimal	AM200™	Stk.	TiN	Stk.	TiAlN	Stk.	TiCN	Stk.
	26.50	1.0433"	1C22H-26.5	◆	1C22T-26.5	○	1C22A-26.5	●	1C22N-26.5	◆
1 ³ / ₆₄ "	26.59	1.0469"	1C22H-1.046	◆	1C22T-1.046	○	1C22A-1.046	○	1C22N-1.046	◆
1 ¹ / ₁₆ "	26.99	1.0625"	1C22H-0102	◆	1C22T-0102	○	1C22A-0102	○	1C22N-0102	◆
	27.00	1.0630"	1C22H-27	◆	1C22T-27	●	1C22A-27	●	1C22N-27	◆
	27.50	1.0827"	1C22H-27.5	◆	1C22T-27.5	○	1C22A-27.5	●	1C22N-27.5	◆
1 ³ / ₃₂ "	27.78	1.0938"	1C22H-0103	◆	1C22T-0103	○	1C22A-0103	○	1C22N-0103	◆
	28.00	1.1024"	1C22H-28	◆	1C22T-28	●	1C22A-28	●	1C22N-28	◆
1 ⁷ / ₆₄ "	28.18	1.1094"	1C22H-1.109	◆	1C22T-1.109	○	1C22A-1.109	○	1C22N-1.109	◆
	28.50	1.1220"	1C22H-28.5	◆	1C22T-28.5	○	1C22A-28.5	●	1C22N-28.5	◆
1 ¹ / ₈ "	28.58	1.1250"	1C22H-0104	◆	1C22T-0104	○	1C22A-0104	○	1C22N-0104	◆
	29.00	1.1417"	1C22H-29	◆	1C22T-29	●	1C22A-29	●	1C22N-29	◆
1 ⁵ / ₃₂ "	29.37	1.1563"	1C22H-0105	◆	1C22T-0105	○	1C22A-0105	○	1C22N-0105	◆
	29.50	1.1614"	1C22H-29.5	◆	1C22T-29.5	○	1C22A-29.5	●	1C22N-29.5	◆
	30.00	1.1811"	1C22H-30	◆	1C22T-30	●	1C22A-30	●	1C22N-30	◆
1 ³ / ₁₆ "	30.16	1.1875"	1C22H-0106	◆	1C22T-0106	○	1C22A-0106	○	1C22N-0106	◆
	30.50	1.2007"	1C22H-30.5	◆	1C22T-30.5	○	1C22A-30.5	●	1C22N-30.5	◆
1 ⁷ / ₃₂ "	30.96	1.2188"	1C22H-0107	◆	1C22T-0107	○	1C22A-0107	○	1C22N-0107	◆
	31.00	1.2205"	1C22H-31	◆	1C22T-31	●	1C22A-31	●	1C22N-31	◆
	31.50	1.2402"	1C22H-31.5	◆	1C22T-31.5	○	1C22A-31.5	●	1C22N-31.5	◆
1 ¹ / ₄ "	31.75	1.2500"	1C22H-0108	◆	1C22T-0108	○	1C22A-0108	○	1C22N-0108	◆
	32.00	1.2598"	1C22H-32	◆	1C22T-32	●	1C22A-32	●	1C22N-32	◆
	32.50	1.2795"	1C22H-32.5	◆	1C22T-32.5	○	1C22A-32.5	●	1C22N-32.5	◆
1 ⁹ / ₃₂ "	32.54	1.2813"	1C22H-0109	◆	1C22T-0109	○	1C22A-0109	○	1C22N-0109	◆
	33.00	1.2992"	1C22H-33	◆	1C22T-33	●	1C22A-33	●	1C22N-33	◆
1 ⁵ / ₁₆ "	33.34	1.3125"	1C22H-0110	◆	1C22T-0110	○	1C22A-0110	○	1C22N-0110	◆
	33.50	1.3189"	1C22H-33.5	◆	1C22T-33.5	○	1C22A-33.5	●	1C22N-33.5	◆
	34.00	1.3386"	1C22H-34	◆	1C22T-34	●	1C22A-34	●	1C22N-34	◆
1 ¹¹ / ₃₂ "	34.13	1.3438"	1C22H-0111	◆	1C22T-0111	○	1C22A-0111	○	1C22N-0111	◆
	34.50	1.3583"	1C22H-34.5	◆	1C22T-34.5	○	1C22A-34.5	●	1C22N-34.5	◆
1 ³ / ₈ "	34.93	1.3750"	1C22H-0112	◆	1C22T-0112	○	1C22A-0112	○	1C22N-0112	◆
	35.00	1.3780"	1C22H-35	◆	1C22T-35	●	1C22A-35	●	1C22N-35	◆

Supplied in 2 piece packages.

2 Series Standard T-A® K10 Carbide

Diameter Range 24.41 to 35.05

AMEC's K10 insert is specifically designed for drilling grey/white cast irons. The special geometry offers substantial increases in penetration rates and provides exceptional edge strength and tool life.



3 ¹ / ₃₂ "	24.61	.9688"	1C32H-0031-CI	◆	1C32T-0031-CI	◆	1C32A-0031-CI	○	1C32N-0031-CI	◆
6 ³ / ₆₄ "	25.00	.9843"	1C32H-25-CI	◆	1C32T-25-CI	◆	1C32A-25-CI	●	1C32N-25-CI	◆
1"	25.40	1.0000"	1C32H-0100-CI	◆	1C32T-0100-CI	◆	1C32A-0100-CI	○	1C32N-0100-CI	◆
	26.00	1.0236"	1C32H-26-CI	◆	1C32T-26-CI	◆	1C32A-26-CI	●	1C32N-26-CI	◆
1 ¹ / ₃₂ "	26.19	1.0313"	1C32H-0101-CI	◆	1C32T-0101-CI	◆	1C32A-0101-CI	○	1C32N-0101-CI	◆
1 ³ / ₆₄ "	26.59	1.0469"	1C32H-1.046-CI	◆	1C32T-1.046-CI	◆	1C32A-1.046-CI	○	1C32N-1.046-CI	◆
1 ¹ / ₁₆ "	26.99	1.0625"	1C32H-0102-CI	◆	1C32T-0102-CI	◆	1C32A-0102-CI	○	1C32N-0102-CI	◆
	27.00	1.0630"	1C32H-27-CI	◆	1C32T-27-CI	◆	1C32A-27-CI	●	1C32N-27-CI	◆
1 ³ / ₃₂ "	27.78	1.0938"	1C32H-0103-CI	◆	1C32T-0103-CI	◆	1C32A-0103-CI	○	1C32N-0103-CI	◆
	28.00	1.1024"	1C32H-28-CI	◆	1C32T-28-CI	◆	1C32A-28-CI	●	1C32N-28-CI	◆
1 ⁷ / ₆₄ "	28.18	1.1094"	1C32H-1.109-CI	◆	1C32T-1.109-CI	◆	1C32A-1.109-CI	○	1C32N-1.109-CI	◆
1 ¹ / ₈ "	28.58	1.1250"	1C32H-0104-CI	◆	1C32T-0104-CI	◆	1C32A-0104-CI	○	1C32N-0104-CI	◆
	29.00	1.1417"	1C32H-29-CI	◆	1C32T-29-CI	◆	1C32A-29-CI	●	1C32N-29-CI	◆
1 ⁵ / ₃₂ "	29.37	1.1563"	1C32H-0105-CI	◆	1C32T-0105-CI	◆	1C32A-0105-CI	○	1C32N-0105-CI	◆
	30.00	1.1811"	1C32H-30-CI	◆	1C32T-30-CI	◆	1C32A-30-CI	●	1C32N-30-CI	◆
1 ³ / ₁₆ "	30.16	1.1875"	1C32H-0106-CI	◆	1C32T-0106-CI	◆	1C32A-0106-CI	○	1C32N-0106-CI	◆
1 ⁷ / ₃₂ "	30.96	1.2188"	1C32H-0107-CI	◆	1C32T-0107-CI	◆	1C32A-0107-CI	○	1C32N-0107-CI	◆



2 Series T-A® Drill Inserts

2 Series Standard T-A® K10 Carbide

Diameter Range 24.41 to 35.05

AMEC's K10 insert is specifically designed for drilling grey/white cast irons. The special geometry offers substantial increases in penetration rates and provides exceptional edge strength and tool life.



Diameter			Item Number, Coating and Availability							
Ø Inch	Ø mm	Ø Decimal	AM200™	Stk.	TiN	Stk.	TiAlN	Stk.	TiCN	Stk.
1¼"	31.00	1.2205"	1C32H-31-CI	◆	1C32T-31-CI	◆	1C32A-31-CI	●	1C32N-31-CI	◆
	31.75	1.2500"	1C32H-0108-CI	◆	1C32T-0108-CI	◆	1C32A-0108-CI	○	1C32N-0108-CI	◆
	32.00	1.2598"	1C32H-32-CI	◆	1C32T-32-CI	◆	1C32A-32-CI	●	1C32N-32-CI	◆
1⅜"	32.54	1.2813"	1C32H-0109-CI	◆	1C32T-0109-CI	◆	1C32A-0109-CI	○	1C32N-0109-CI	◆
	33.00	1.2992"	1C32H-33-CI	◆	1C32T-33-CI	◆	1C32A-33-CI	●	1C32N-33-CI	◆
1⅝"	33.34	1.3125"	1C32H-0110-CI	◆	1C32T-0110-CI	○	1C32A-0110-CI	○	1C32N-0110-CI	◆
	34.00	1.3386"	1C32H-34-CI	◆	1C32T-34-CI	●	1C32A-34-CI	●	1C32N-34-CI	◆
1⅞"	34.13	1.3438"	1C32H-0111-CI	◆	1C32T-0111-CI	○	1C32A-0111-CI	○	1C32N-0111-CI	◆
1¾"	34.93	1.3750"	1C32H-0112-CI	◆	1C32T-0112-CI	○	1C32A-0112-CI	○	1C32N-0112-CI	◆
	35.00	1.3780"	1C32H-35-CI	◆	1C32T-35-CI	●	1C32A-35-CI	●	1C32N-35-CI	◆

2 Series Standard T-A® P40 Carbide

Diameter Range 24.41 to 35.05

Excellent choice for drilling, free machining steel, low/medium carbon steels, alloy steels, high strength steels, tool steels, hardened steels, and certain stainless steels refer to technical section.



3⅜"	24.61	.9688"	1C52H-0031	◆	1C52T-0031	○	1C52A-0031	○	1C52N-0031	◆
6⅜"	25.00	.9843"	1C52H-25	◆	1C52T-25	●	1C52A-25	●	1C52N-25	◆
1"	25.40	1.0000"	1C52H-0100	◆	1C52T-0100	○	1C52A-0100	○	1C52N-0100	◆
	26.00	1.0236"	1C52H-26	◆	1C52T-26	●	1C52A-26	●	1C52N-26	◆
1⅓"	26.19	1.0313"	1C52H-0101	◆	1C52T-0101	○	1C52A-0101	○	1C52N-0101	◆
1⅜"	26.59	1.0469"	1C52H-1.046	◆	1C52T-1.046	○	1C52A-1.046	○	1C52N-1.046	◆
1⅝"	26.99	1.0625"	1C52H-0102	◆	1C52T-0102	○	1C52A-0102	○	1C52N-0102	◆
	27.00	1.0630"	1C52H-27	◆	1C52T-27	●	1C52A-27	●	1C52N-27	◆
1⅞"	27.78	1.0938"	1C52H-0103	◆	1C52T-0103	○	1C52A-0103	○	1C52N-0103	◆
	28.00	1.1024"	1C52H-28	◆	1C52T-28	●	1C52A-28	●	1C52N-28	◆
1⅞"	28.18	1.1094"	1C52H-1.109	◆	1C52T-1.109	○	1C52A-1.109	○	1C52N-1.109	◆
1¾"	28.58	1.1250"	1C52H-0104	◆	1C52T-0104	○	1C52A-0104	○	1C52N-0104	◆
	29.00	1.1417"	1C52H-29	◆	1C52T-29	●	1C52A-29	●	1C52N-29	◆
1⅝"	29.37	1.1563"	1C52H-0105	◆	1C52T-0105	○	1C52A-0105	○	1C52N-0105	◆
	30.00	1.1811"	1C52H-30	◆	1C52T-30	●	1C52A-30	●	1C52N-30	◆
1⅞"	30.16	1.1875"	1C52H-0106	◆	1C52T-0106	○	1C52A-0106	○	1C52N-0106	◆
1⅞"	30.96	1.2188"	1C52H-0107	◆	1C52T-0107	○	1C52A-0107	○	1C52N-0107	◆
	31.00	1.2205"	1C52H-31	◆	1C52T-31	●	1C52A-31	●	1C52N-31	◆
1¼"	31.75	1.2500"	1C52H-0108	◆	1C52T-0108	○	1C52A-0108	○	1C52N-0108	◆
	32.00	1.2598"	1C52H-32	◆	1C52T-32	●	1C52A-32	●	1C52N-32	◆
1⅜"	32.54	1.2813"	1C52H-0109	◆	1C52T-0109	○	1C52A-0109	○	1C52N-0109	◆
	33.00	1.2992"	1C52H-33	◆	1C52T-33	●	1C52A-33	●	1C52N-33	◆
1⅝"	33.34	1.3125"	1C52H-0110	◆	1C52T-0110	○	1C52A-0110	○	1C52N-0110	◆
	34.00	1.3386"	1C52H-34	◆	1C52T-34	●	1C52A-34	●	1C52N-34	◆
1⅞"	34.13	1.3438"	1C52H-0111	◆	1C52T-0111	○	1C52A-0111	○	1C52N-0111	◆
	34.93	1.3750"	1C52H-0112	◆	1C52T-0112	○	1C52A-0112	○	1C52N-0112	◆
1¾"	35.00	1.3780"	1C52H-35	◆	1C52T-35	●	1C52A-35	●	1C52N-35	◆

Supplied in 2 piece packages.

Stk. - Stock Availability.

- Stock Item.
- Stocked in limited quantities, advanced planning is recommended.
- ◆ Non-stock standard. Normal delivery 5 to 6 weeks.

Any non-standard size available.

2 Series T-A® Drill Inserts



2 Series Standard T-A® HSS Super Cobalt - Flat Bottom

Diameter Range 24.41 to 35.05

First choice for flattening or squaring bottom of pre-existing holes. Tools with this geometry are normally sized the same diameter as hole. However, this style of insert when used with stub or short length holder may be used to Counterbore holes smaller than the tool diameter. The patented geometry provides an efficient and stable cutting action in all materials.



Diameter			Item Number, Coating and Availability							
Ø Inch	Ø mm	Ø Decimal	AM200™	Stk.	TiN	Stk.	TiAlN	Stk.	TiCN	Stk.
3 ¹ / ₃₂ "	24.61	.9688"	152H-0031-FB	◆	152T-0031-FB	○	152A-0031-FB	◆	152N-0031-FB	◆
6 ³ / ₆₄ "	25.00	.9843"	152H-25-FB	◆	152T-25-FB	○	152A-25-FB	◆	152N-25-FB	◆
1"	25.40	1.0000"	152H-0100-FB	◆	152T-0100-FB	○	152A-0100-FB	◆	152N-0100-FB	◆
1 ¹ / ₆₄ "	25.80	1.0156"	152H-1.015-FB	◆	152T-1.015-FB	○	152A-1.015-FB	◆	152N-1.015-FB	◆
	26.00	1.0236"	152H-26-FB	◆	152T-26-FB	○	152A-26-FB	◆	152N-26-FB	◆
1 ¹ / ₃₂ "	26.19	1.0313"	152H-0101-FB	◆	152T-0101-FB	○	152A-0101-FB	◆	152N-0101-FB	◆
1 ¹ / ₁₆ "	26.99	1.0625"	152H-0102-FB	◆	152T-0102-FB	○	152A-0102-FB	◆	152N-0102-FB	◆
	27.00	1.0630"	152H-27-FB	◆	152T-27-FB	○	152A-27-FB	◆	152N-27-FB	◆
1 ³ / ₃₂ "	27.78	1.0938"	152H-0103-FB	◆	152T-0103-FB	○	152A-0103-FB	◆	152N-0103-FB	◆
	28.00	1.1024"	152H-28-FB	◆	152T-28-FB	○	152A-28-FB	◆	152N-28-FB	◆
1 ¹ / ₈ "	28.58	1.1250"	152H-0104-FB	◆	152T-0104-FB	○	152A-0104-FB	◆	152N-0104-FB	◆
	29.00	1.1417"	152H-29-FB	◆	152T-29-FB	○	152A-29-FB	◆	152N-29-FB	◆
1 ⁵ / ₃₂ "	29.37	1.1563"	152H-0105-FB	◆	152T-0105-FB	○	152A-0105-FB	◆	152N-0105-FB	◆
	30.00	1.1811"	152H-30-FB	◆	152T-30-FB	○	152A-30-FB	◆	152N-30-FB	◆
1 ³ / ₁₆ "	30.16	1.1875"	152H-0106-FB	◆	152T-0106-FB	○	152A-0106-FB	◆	152N-0106-FB	◆
1 ⁷ / ₃₂ "	30.96	1.2188"	152H-0107-FB	◆	152T-0107-FB	○	152A-0107-FB	◆	152N-0107-FB	◆
	31.00	1.2205"	152H-31-FB	◆	152T-31-FB	○	152A-31-FB	◆	152N-31-FB	◆
1 ¹ / ₄ "	31.75	1.2500"	152H-0108-FB	◆	152T-0108-FB	○	152A-0108-FB	◆	152N-0108-FB	◆
	32.00	1.2598"	152H-32-FB	◆	152T-32-FB	○	152A-32-FB	◆	152N-32-FB	◆
1 ⁹ / ₃₂ "	32.54	1.2813"	152H-0109-FB	◆	152T-0109-FB	○	152A-0109-FB	◆	152N-0109-FB	◆
	33.00	1.2992"	152H-33-FB	◆	152T-33-FB	○	152A-33-FB	◆	152N-33-FB	◆
1 ⁵ / ₁₆ "	33.34	1.3125"	152H-0110-FB	◆	152T-0110-FB	○	152A-0110-FB	◆	152N-0110-FB	◆
	34.00	1.3386"	152H-34-FB	◆	152T-34-FB	○	152A-34-FB	◆	152N-34-FB	◆
1 ¹¹ / ₃₂ "	34.13	1.3438"	152H-0111-FB	◆	152T-0111-FB	○	152A-0111-FB	◆	152N-0111-FB	◆
1 ³ / ₈ "	34.93	1.3750"	152H-0112-FB	◆	152T-0112-FB	○	152A-0112-FB	◆	152N-0112-FB	◆
	35.00	1.3780"	152H-35-FB	◆	152T-35-FB	○	152A-35-FB	◆	152N-35-FB	◆

Supplied in 2 piece packages.

2 Series Standard T-A® K20 Carbide - Flat Bottom

Diameter Range 24.41 to 35.05

First choice for flattening or squaring bottom of pre-existing holes with high rigidity. Tools with this geometry are normally sized the same diameter as hole. However, this style of insert when used with stub or short length holder may be used to Counterbore holes smaller than the tool diameter. The patented geometry provides an efficient and stable cutting action in all materials.



3 ¹ / ₃₂ "	24.61	.9688"	1C22H-0031-FB	◆	1C22T-0031-FB	◆	1C22A-0031-FB	◆	1C22N-0031-FB	◆
6 ³ / ₆₄ "	25.00	.9843"	1C22H-25-FB	◆	1C22T-25-FB	◆	1C22A-25-FB	◆	1C22N-25-FB	◆
1"	25.40	1.0000"	1C22H-0100-FB	◆	1C22T-0100-FB	◆	1C22A-0100-FB	◆	1C22N-0100-FB	◆
1 ¹ / ₆₄ "	25.80	1.0156"	1C22H-1.015-FB	◆	1C22T-1.015-FB	◆	1C22A-1.015-FB	◆	1C22N-1.015-FB	◆
	26.00	1.0236"	1C22H-26-FB	◆	1C22T-26-FB	◆	1C22A-26-FB	◆	1C22N-26-FB	◆
1 ¹ / ₃₂ "	26.19	1.0313"	1C22H-0101-FB	◆	1C22T-0101-FB	◆	1C22A-0101-FB	◆	1C22N-0101-FB	◆
1 ¹ / ₁₆ "	26.99	1.0625"	1C22H-0102-FB	◆	1C22T-0102-FB	◆	1C22A-0102-FB	◆	1C22N-0102-FB	◆
	27.00	1.0630"	1C22H-27-FB	◆	1C22T-27-FB	◆	1C22A-27-FB	◆	1C22N-27-FB	◆
1 ³ / ₃₂ "	27.78	1.0938"	1C22H-0103-FB	◆	1C22T-0103-FB	◆	1C22A-0103-FB	◆	1C22N-0103-FB	◆
	28.00	1.1024"	1C22H-28-FB	◆	1C22T-28-FB	◆	1C22A-28-FB	◆	1C22N-28-FB	◆
1 ¹ / ₈ "	28.58	1.1250"	1C22H-0104-FB	◆	1C22T-0104-FB	◆	1C22A-0104-FB	◆	1C22N-0104-FB	◆
	29.00	1.1417"	1C22H-29-FB	◆	1C22T-29-FB	◆	1C22A-29-FB	◆	1C22N-29-FB	◆
1 ⁵ / ₃₂ "	29.37	1.1563"	1C22H-0105-FB	◆	1C22T-0105-FB	◆	1C22A-0105-FB	◆	1C22N-0105-FB	◆
	30.00	1.1811"	1C22H-30-FB	◆	1C22T-30-FB	◆	1C22A-30-FB	◆	1C22N-30-FB	◆
1 ³ / ₁₆ "	30.16	1.1875"	1C22H-0106-FB	◆	1C22T-0106-FB	◆	1C22A-0106-FB	◆	1C22N-0106-FB	◆
1 ⁷ / ₃₂ "	30.96	1.2188"	1C22H-0107-FB	◆	1C22T-0107-FB	◆	1C22A-0107-FB	◆	1C22N-0107-FB	◆
	31.00	1.2205"	1C22H-31-FB	◆	1C22T-31-FB	◆	1C22A-31-FB	◆	1C22N-31-FB	◆
1 ¹ / ₄ "	31.75	1.2500"	1C22H-0108-FB	◆	1C22T-0108-FB	◆	1C22A-0108-FB	◆	1C22N-0108-FB	◆

Supplied in 2 piece packages.



2 Series T-A® Drill Inserts

2 Series Standard T-A® K20 Carbide - Flat Bottom

Diameter Range 24.41 to 35.05

First choice for flattening or squaring bottom of pre-existing holes with high rigidity. Tools with this geometry are normally sized the same diameter as hole. However, this style of insert when used with stub or short length holder may be used to Counterbore holes smaller than the tool diameter. The patented geometry provides an efficient and stable cutting action in all materials.



Diameter			Item Number, Coating and Availability							
Ø Inch	Ø mm	Ø Decimal	AM200™	Stk.	TiN	Stk.	TiAlN	Stk.	TiCN	Stk.
1 3/32"	32.00	1.2598"	1C22H-32-FB	◆	1C22T-32-FB	◆	1C22A-32-FB	◆	1C22N-32-FB	◆
	32.54	1.2813"	1C22H-0109-FB	◆	1C22T-0109-FB	◆	1C22A-0109-FB	◆	1C22N-0109-FB	◆
1 5/16"	33.00	1.2992"	1C22H-33-FB	◆	1C22T-33-FB	◆	1C22A-33-FB	◆	1C22N-33-FB	◆
	33.34	1.3125"	1C22H-0110-FB	◆	1C22T-0110-FB	◆	1C22A-0110-FB	◆	1C22N-0110-FB	◆
1 1/2"	34.00	1.3386"	1C22H-34-FB	◆	1C22T-34-FB	◆	1C22A-34-FB	◆	1C22N-34-FB	◆
	34.13	1.3438"	1C22H-0111-FB	◆	1C22T-0111-FB	◆	1C22A-0111-FB	◆	1C22N-0111-FB	◆
1 3/8"	34.93	1.3750"	1C22H-0112-FB	◆	1C22T-0112-FB	◆	1C22A-0112-FB	◆	1C22N-0112-FB	◆
	35.00	1.3780"	1C22H-35-FB	◆	1C22T-35-FB	◆	1C22A-35-FB	◆	1C22N-35-FB	◆

Supplied in 2 piece packages.

2 Series Standard T-A® HSS Super Cobalt - 90° Spot and Chamfer

Diameter Range 24.41 to 35.05

Highly efficient geometry is combined with a centre cutting web designed to improve stability and strength. The primary use is to spot and chamfer, eliminating the need for secondary operations. One tool will cover a wide application range by simply adjusting the depth.



3 1/32"	24,61	.9688"	152H-0031-SP	◆	152T-0031-SP	◆	152A-0031-SP	◆	152N-0031-SP	◆
6 3/64"	25,00	.9843"	152H-25-SP	◆	152T-25-SP	◆	152A-25-SP	◆	152N-25-SP	◆
1"	25,40	1.0000"	152H-0100-SP	◆	152T-0100-SP	◆	152A-0100-SP	◆	152N-0100-SP	◆
1 1/64"	25,80	1.0156"	152H-1.015-SP	◆	152T-1.015-SP	◆	152A-1.015-SP	◆	152N-1.015-SP	◆
	26,00	1.0236"	152H-26-SP	◆	152T-26-SP	◆	152A-26-SP	◆	152N-26-SP	◆
1 1/32"	26,19	1.0313"	152H-0101-SP	◆	152T-0101-SP	◆	152A-0101-SP	◆	152N-0101-SP	◆
1 3/64"	26,59	1.0469"	152H-1.046-SP	◆	152T-1.046-SP	◆	152A-1.046-SP	◆	152N-1.046-SP	◆
1 1/16"	26,99	1.0625"	152H-0102-SP	◆	152T-0102-SP	◆	152A-0102-SP	◆	152N-0102-SP	◆
	27,00	1.0630"	152H-27-SP	◆	152T-27-SP	◆	152A-27-SP	◆	152N-27-SP	◆
1 3/32"	27,78	1.0938"	152H-0103-SP	◆	152T-0103-SP	◆	152A-0103-SP	◆	152N-0103-SP	◆
	28,00	1.1024"	152H-28-SP	◆	152T-28-SP	◆	152A-28-SP	◆	152N-28-SP	◆
1 7/64"	28,18	1.1094"	152H-1.109-SP	◆	152T-1.109-SP	◆	152A-1.109-SP	◆	152N-1.109-SP	◆
1 1/8"	28,58	1.1250"	152H-0104-SP	◆	152T-0104-SP	◆	152A-0104-SP	◆	152N-0104-SP	◆
	29,00	1.1417"	152H-29-SP	◆	152T-29-SP	◆	152A-29-SP	◆	152N-29-SP	◆
1 5/32"	29,37	1.1563"	152H-0105-SP	◆	152T-0105-SP	◆	152A-0105-SP	◆	152N-0105-SP	◆
	30,00	1.1811"	152H-30-SP	◆	152T-30-SP	◆	152A-30-SP	◆	152N-30-SP	◆
1 3/16"	30,16	1.1875"	152H-0106-SP	◆	152T-0106-SP	◆	152A-0106-SP	◆	152N-0106-SP	◆
1 7/32"	30,96	1.2188"	152H-0107-SP	◆	152T-0107-SP	◆	152A-0107-SP	◆	152N-0107-SP	◆
	31,00	1.2205"	152H-31-SP	◆	152T-31-SP	◆	152A-31-SP	◆	152N-31-SP	◆
1 1/4"	31,75	1.2500"	152H-0108-SP	◆	152T-0108-SP	◆	152A-0108-SP	◆	152N-0108-SP	◆
	32,00	1.2598"	152H-32-SP	◆	152T-32-SP	◆	152A-32-SP	◆	152N-32-SP	◆
1 9/32"	32,54	1.2813"	152H-0109-SP	◆	152T-0109-SP	◆	152A-0109-SP	◆	152N-0109-SP	◆
	33,00	1.2992"	152H-33-SP	◆	152T-33-SP	◆	152A-33-SP	◆	152N-33-SP	◆
1 5/16"	33,34	1.3125"	152H-0110-SP	◆	152T-0110-SP	◆	152A-0110-SP	◆	152N-0110-SP	◆
	34,00	1.3386"	152H-34-SP	◆	152T-34-SP	◆	152A-34-SP	◆	152N-34-SP	◆
1 1 1/32"	34,13	1.3438"	152H-0111-SP	◆	152T-0111-SP	◆	152A-0111-SP	◆	152N-0111-SP	◆
	34,93	1.3750"	152H-0112-SP	◆	152T-0112-SP	◆	152A-0112-SP	◆	152N-0112-SP	◆
1 3/8"	35,00	1.3780"	152H-35-SP	◆	152T-35-SP	●	152A-35-SP	○	152N-35-SP	○

Supplied in 2 piece packages.



2 Series Standard T-A® N2 Carbide - CVD Diamond Coated

Diameter Range 24.41 to 35.05

AMEC's Diamond film inserts combine the best features of a tough carbide substrate with a hard durable Crystalline Diamond CVD coating. A tool life increase of 30 - 50 times over uncoated carbide inserts can be achieved in non ferrous/non metallic materials.

Page 72 refers for technical help.



Diameter			Item Number, Coating and Availability	
Ø Inch	Ø mm	Ø Decimal	CVD Diamond Coated	Stk.
3 ¹ / ₃₂ "	24.61	.9688"	1N22D-0031	◆
6 ³ / ₆₄ "	25.00	.9843"	1N22D-25	◆
1"	25.40	1.0000"	1N22D-0100	◆
1 ¹ / ₆₄ "	25.80	1.0156"	1N22D-1.015	◆
	26.00	1.0236"	1N22D-26	◆
1 ¹ / ₃₂ "	26.19	1.0313"	1N22D-0101	◆
1 ³ / ₆₄ "	26.59	1.0469"	1N22D-1.046	◆
1 ¹ / ₁₆ "	26.99	1.0625"	1N22D-0102	◆
	27.00	1.0630"	1N22D-27	◆
1 ³ / ₃₂ "	27.78	1.0938"	1N22D-0103	◆
	28.00	1.1024"	1N22D-28	◆
1 ⁷ / ₆₄ "	28.18	1.1094"	1N22D-1.109	◆
1 ¹ / ₈ "	28.58	1.1250"	1N22D-0104	◆
	29.00	1.1417"	1N22D-29	◆
1 ⁵ / ₃₂ "	29.37	1.1563"	1N22D-0105	◆
	30.00	1.1811"	1N22D-30	◆
1 ³ / ₁₆ "	30.16	1.1875"	1N22D-0106	◆
1 ⁷ / ₃₂ "	30.96	1.2188"	1N22D-0107	◆
	31.00	1.2205"	1N22D-31	◆
1 ¹ / ₄ "	31.75	1.2500"	1N22D-0108	◆
	32.00	1.2598"	1N22D-32	◆
1 ⁹ / ₃₂ "	32.54	1.2813"	1N22D-0109	◆
	33.00	1.2992"	1N22D-33	◆
1 ⁵ / ₁₆ "	33.34	1.3125"	1N22D-0110	◆
	34.00	1.3386"	1N22D-34	◆
1 ¹¹ / ₃₂ "	34.13	1.3438"	1N22D-0111	◆
1 ³ / ₈ "	34.93	1.3750"	1N22D-0112	◆
	35.00	1.3780"	1N22D-35	◆

Supplied in 1 piece packages.

Stk. - Stock Availability.

- Stock Item.
- Stocked in limited quantities, advanced planning is recommended.
- ◆ Non-stock standard. Normal delivery 5 to 6 weeks.

Any non-standard size available.