

Spannzange / collet ER32 DIN6499
 Spannungsbereich / clamping range: 2,0 - 20,0

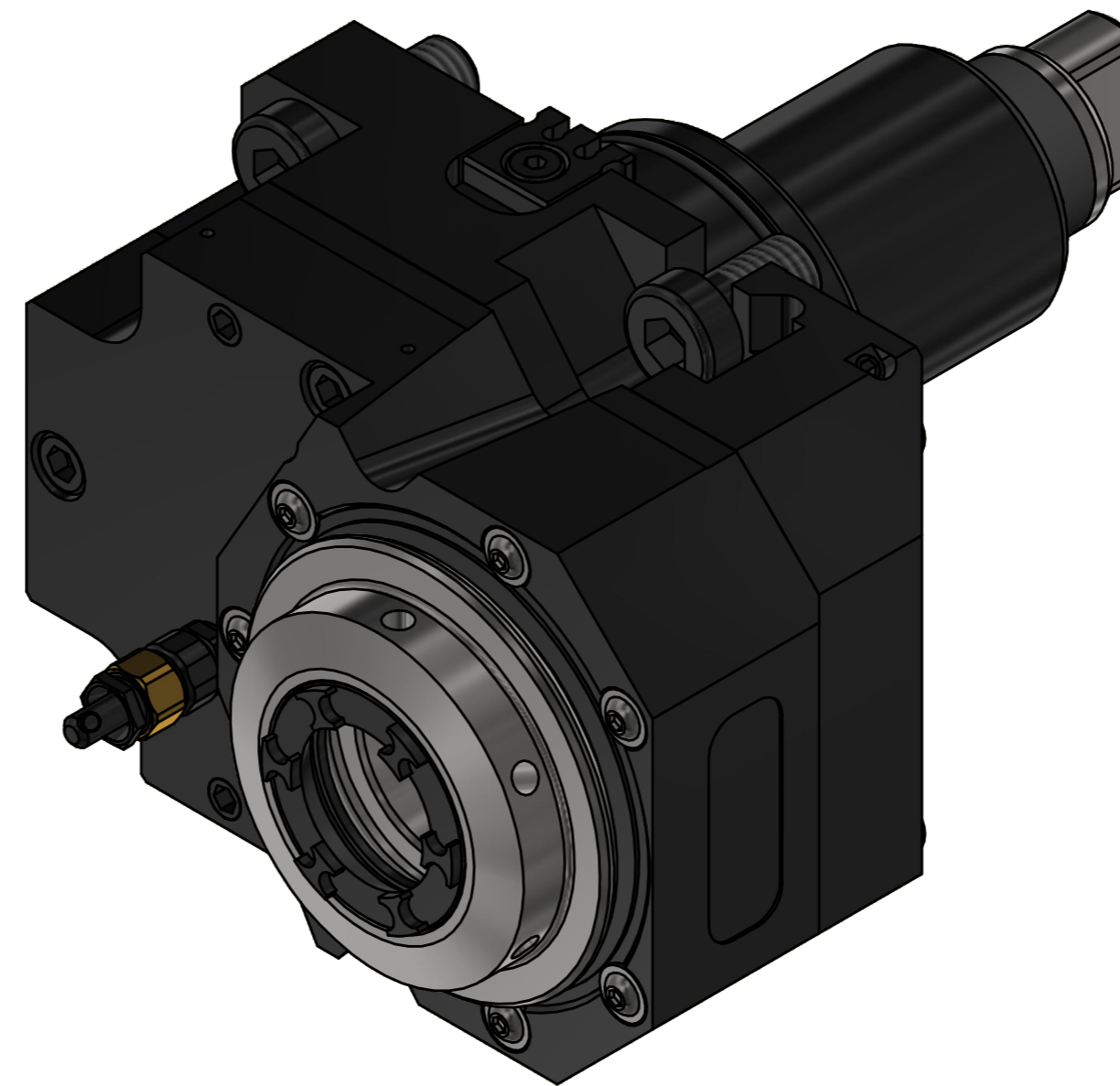

Spannzangenschlüssel für innenliegende Mutter
 Clamping wrench for internal collet
 232AX

Hakenschlüssel mit Zapfen
 Hook wrench with fixed pin
 DIN1810 B 58x62

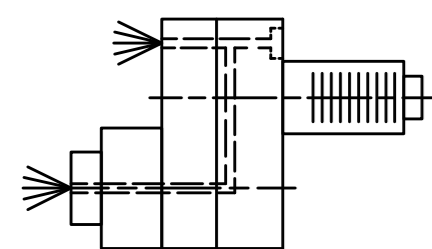

Innen- und Aussenkuehlung / Inside and outside coolant supply
 Kuehlmittelfiltrierung-50µ / coolant filtration-50µ

Bemerkung - Note Für Trockenlauf geeignet! Use without coolant fluid allowed!	Technische Daten - technical data Weight = 6.644 [kg] Torque max. (M1/M2) = 63 / 63 [Nm] Speed max. (n1/n2) = 6000 / 6000 [1/min] Gear ratio (i)=n1:n2 = 1:1 Pressure (pmax) = 70 [bar]	Benennung - Title Axial Bohr u. Fräskopf achsversetzt Ax. drill. and mill. head offset	 EWS Weigle GmbH & Co. KG Maybachstr. 1 D-73066 Uhlingen www.ews-tools.de Nr. - No. 542.010602	Technische Änderungen vorbehalten! Subject to technical modifications! REV: -/A MNR.	
---	--	--	---	---	--

Copyright **EWS Tool Technologies**
 Weitergabe und Vervielfältigung dieser Unterlage,
 Verwertung und Mitteilung ihres Inhalts nicht
 gestattet, soweit nicht ausdrücklich zugestanden.
 Zuwiderhandlungen verpflichten zu Schadenersatz.